

1 Shear pins forward

2 Rope guide

3 Spare shear pins

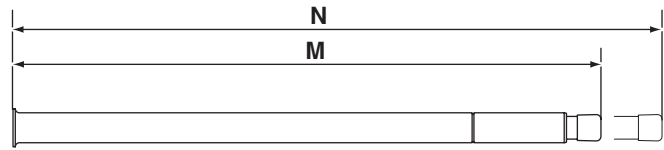

Control lever

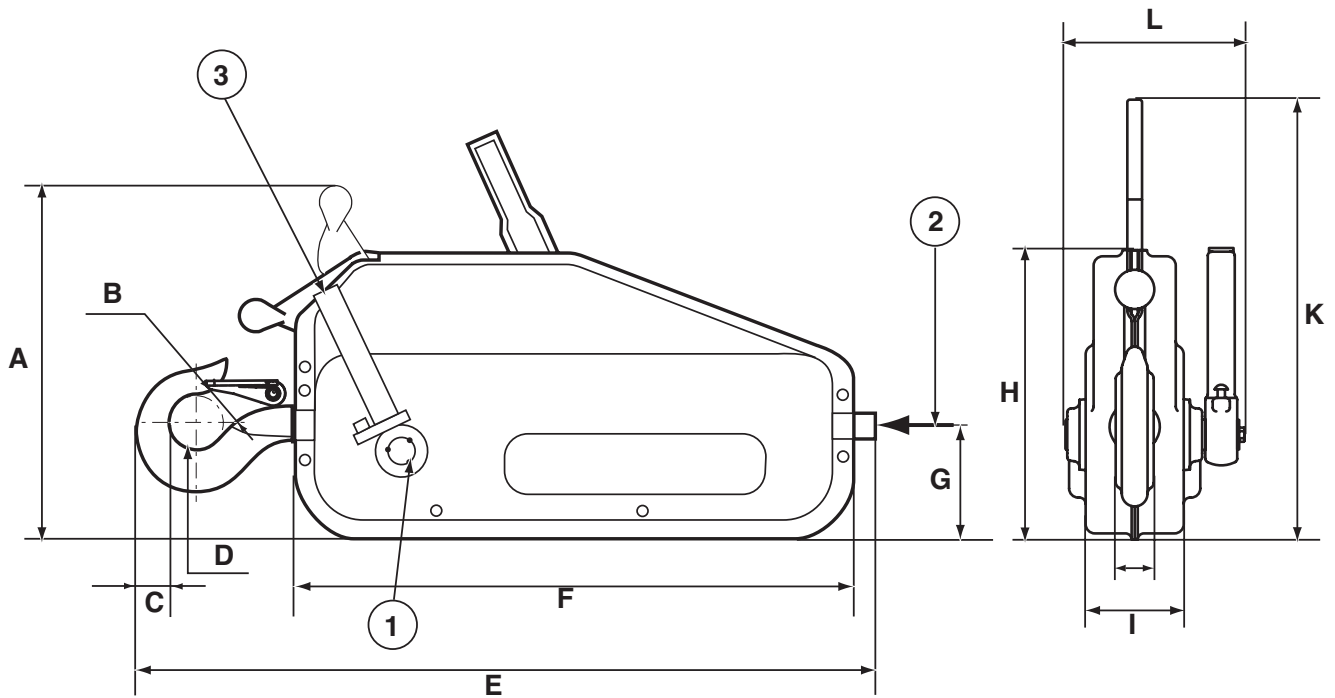

W.L.L.	Ø wire rope	Effort to control lever*		Rope travel*		Dimensions mm													Weight	
		forward kg	reverse kg	forward mm	reverse mm	A	B	C	D	E	F	G	H	I	J	K	L	M		N
800	8.3	43	21	50	60	270	32	30	40	530	397	70	194,5	58	28	285	110	395	620	8.5

* Nominal W.L.L.

- 1 Goupille de sécurité marche avant
- 2 Entrée de câble
- 3 Goupille de sécurité de recharge

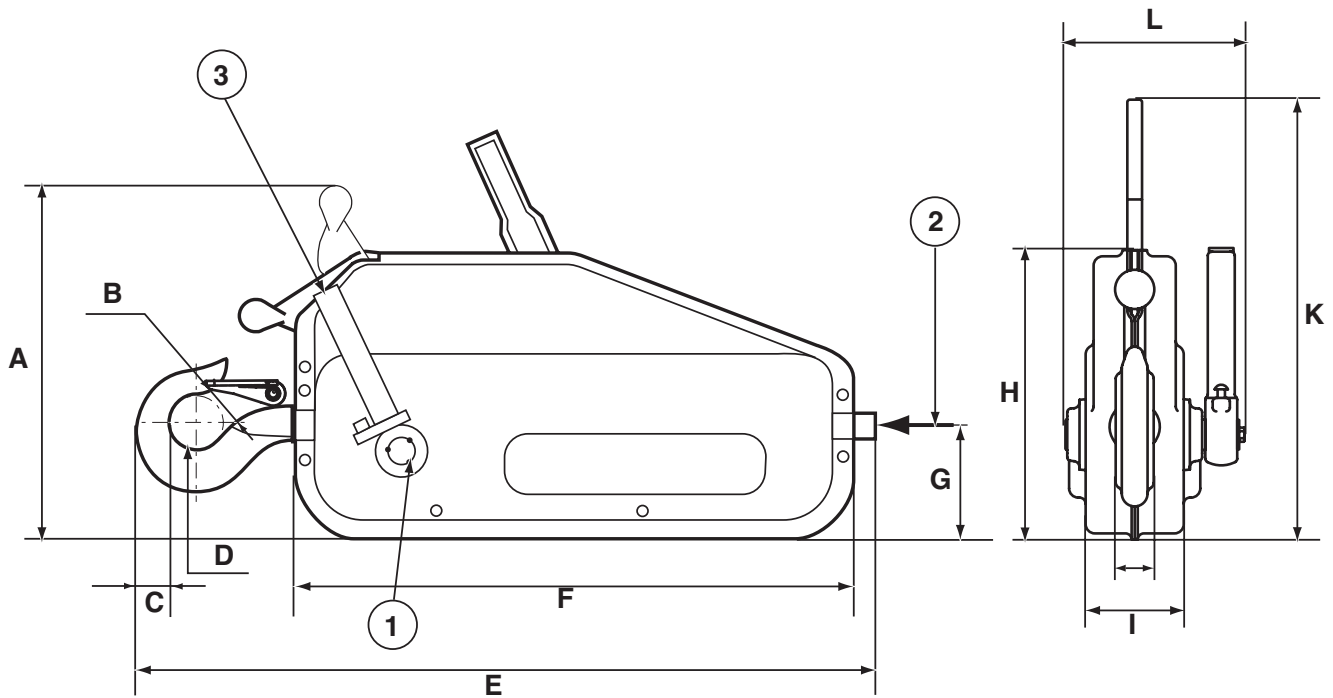
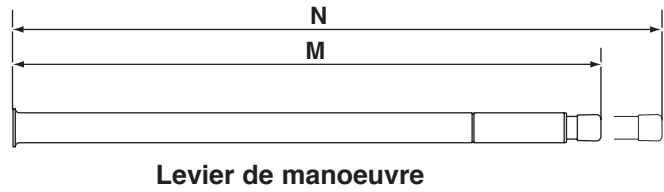

C.M.U.	Ø câble	Effort au levier*		Avance du câble*		Dimensions mm													Poids	
		M. avant kg	M. arrière kg	M. avant mm	M. arrière mm	A	B	C	D	E	F	G	H	I	J	K	L	M		N
800	8.3	43	21	50	60	270	32	30	40	530	397	70	194,5	58	28	285	110	395	620	8.5

* C.M.U. nominale